



NAPCO

OPERATING AND INSTALLATION INSTRUCTIONS

**MARK 5000, 5000R
Telephone Dialer
(Patented)**

NAPCO LIMITED WARRANTY

NAPCO SECURITY SYSTEMS, INC. (NAPCO) warrants its products to be free from manufacturing defects in materials and workmanship for fifteen months following the date of manufacture. NAPCO will, within said period, at its option, repair or replace any product failing to operate correctly without charge to the original purchaser or user.

This warranty shall not apply to any equipment, or any part thereof, which has been repaired by others, improperly installed, improperly used, abused, altered, damaged, subjected to acts of God, or on which any serial numbers have been altered, defaced or removed. Seller will not be responsible for any dismantling or reinstallation charges.

In case of defect, contact the security professional who installed and maintains your security system. NAPCO shall have no obligation under this warranty, or otherwise, if the product has been repaired by others, improperly installed, improperly used, abused, altered, damaged, subjected to accident, nuisance, flood, fire or acts of God, or on which any serial numbers have been altered, defaced or removed. NAPCO will not be responsible for any dismantling, reassembly or reinstallation charges.

In order to exercise the warranty, the product must be returned by the user or purchaser, shipping costs prepaid and insured to NAPCO. After repair or replacement, NAPCO assumes the cost of returning products under warranty.

There are no warranties, express or implied, which extend beyond the description on the face hereof. There is no express or implied warranty of merchantability or a warranty of fitness for a particular purpose. Additionally, this warranty is in lieu of all other obligations or liabilities on the part of NAPCO.

Any action for breach of warranty, including but not limited to any implied warranty of merchantability, must be brought within the six months following the end of the warranty period. In no case shall NAPCO be liable to anyone for any consequential or incidental damages for breach of this or any other warranty, express or implied, even if the loss or damage is caused by the seller's own negligence or fault.

This warranty contains the entire warranty. It is the sole warranty and any prior agreements or representations, whether oral or written, are either merged herein or are expressly cancelled. NAPCO neither assumes, nor authorizes any other person purporting to act on its behalf to modify, to change, or to assume for it, any other warranty or liability concerning its products.

In no event shall NAPCO be liable for an amount in excess of NAPCO's original selling price of the product, for any loss or damage, whether direct, indirect, incidental, consequen-

tial, or otherwise arising out of any failure of the product. Seller's warranty, as hereinabove set forth, shall not be enlarged, diminished or affected by and no obligation or liability shall arise or grow out of Seller's rendering of technical advice or service in connection with Buyer's order of the goods furnished hereunder.

NAPCO RECOMMENDS THAT THE ENTIRE SYSTEM BE COMPLETELY TESTED WEEKLY.

Warning: Despite frequent testing, and due to, but not limited to, any or all of the following: criminal tampering, electrical or communications disruption, it is possible for the system to fail to perform as expected. NAPCO does not represent that the product/system may not be compromised or circumvented; or that the product or system will prevent any personal injury or property loss by burglary, robbery, fire or otherwise; nor that the product or system will in all cases provide adequate warning or protection. A properly installed and maintained alarm may only reduce risk of burglary, robbery, fire or otherwise but it is not insurance or a guarantee that these events will not occur. **CONSEQUENTLY, SELLER SHALL HAVE NO LIABILITY FOR ANY PERSONAL INJURY, PROPERTY DAMAGE, OR OTHER LOSS BASED ON A CLAIM THE PRODUCT FAILED TO GIVE WARNING.** Therefore, the installer should in turn advise the consumer to take any and all precautions for his or her safety including, but not limited to, fleeing the premises and calling police or fire department, in order to mitigate the possibilities of harm and/or damage.

NAPCO is not an insurer of either the property or safety of the user's family or employees, and limits its liability for any loss or damage including incidental or consequential damages to NAPCO's original selling price of the product regardless of the cause of such loss or damage. If the user wishes to protect itself to a greater extent, NAPCO will, at user's sole cost and expense, obtain an insurance policy to protect the user, supplemental to user's own policy, at a premium to be determined by NAPCO's insurer upon written notice from user by Certified Mail, Return Receipt Requested, to NAPCO's home office address, and upon payment of the annual premium cost by user.

Some states do not allow limitations on how long an Implied Warranty lasts or do not allow the exclusion or limitation of incidental or consequential damages, or differentiate in their treatment of limitations of liability for ordinary or gross negligence, so the above limitations or exclusions may not apply to you. This Warranty gives you specific legal rights and you may also have other rights which vary from state to state.

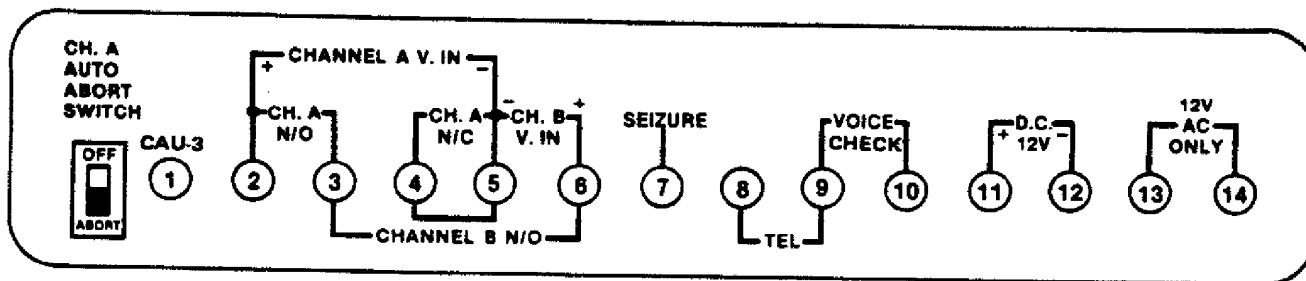

□ AUTOMATIC ABORT SWITCH

Only Channel A can be automatically aborted. This is done by placing the switch, located to the left of the terminals, in the Abort position. If, after an alarm condition has been signaled, the control panel is either shut off or reset, the dialer will automatically abort the message from the telephone line and return itself to a ready condition.

□ TERMINAL 1: CAU-3

This is used only with the Napco CAU-3 Wireless Receiver, and connections should be made as per instructions included with that unit.

□ TERMINALS 2 - 5: DIALER ACTIVATION OF CHANNEL A

Channel A is activated by:

- A voltage (5-18 VDC) across terminals 2 (+) and 5 (-).

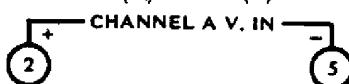

- A dry (contact) closure across terminals 2 & 3, which are for a normally open circuit.

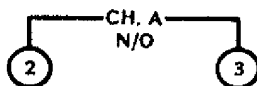

- A combination of voltage and dry inputs are wired to terminals 2, 3, & 5, as shown below. A 600 volt diode (minimum) must be incorporated into the installation.

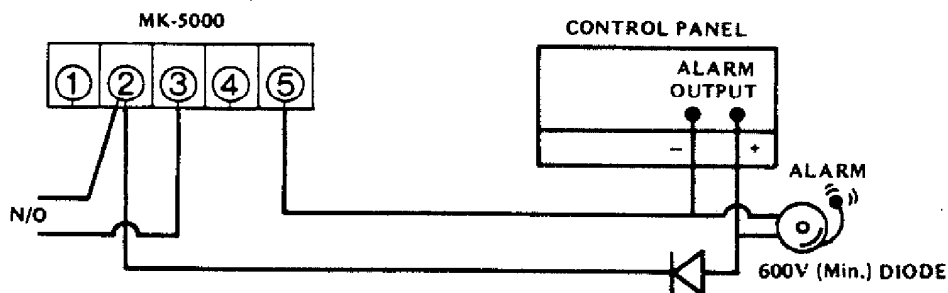

- An opening of the normally closed circuit between terminals 4 & 5 can also activate Channel A. By removing the factory installed jumper (terminals 4 & 5 should never be left open) and setting the automatic abort switch to "Off", a normally closed protective circuit, with a resistance limited to 200 ohms, will be made available.



If desired, an LED (NAPCO D-114 or EQUIVALENT) may be inserted into the normally closed circuit to monitor the condition of the protective loop. The total loop resistance is then limited to 100 ohms.

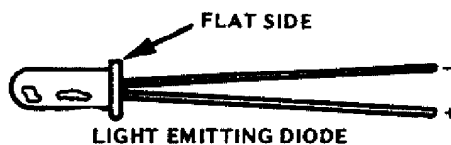
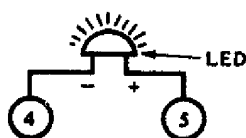

NOTE: LED's have a flat side on their rims to differentiate the polarity of the leads. The lead nearest the flat spot is negative (-) and should be wired towards terminal 4.

TERMINALS 3 - 6: DIALER ACTIVATION OF CHANNEL B (Priority Channel)

Channel B is activated by:

- A voltage (5-18 VDC) across terminals 5 (-) and 6 (+).

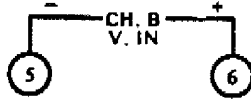

- A dry (contact) closure across terminals 3 & 6, which are for a normally open circuit.



- A combination of voltage and dry inputs are wired to terminals 3, 5, & 6, as shown below. a 600 volt diode (minimum) must be incorporated into the installation.

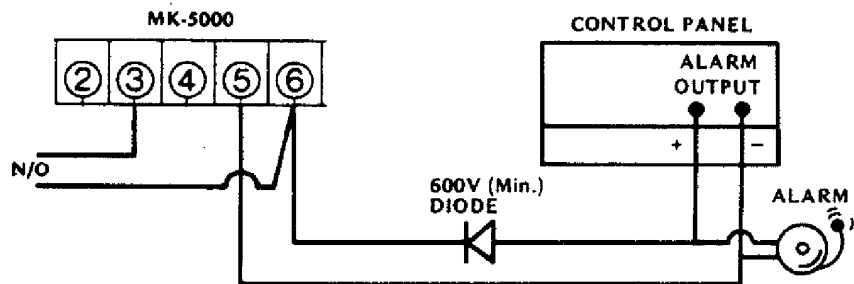

TERMINALS 7, 8, & 9: LINE SEIZURE

The line seizure feature disconnects the building's telephones from the street telephone lines once the dialer is activated, or the TEST switch is pressed. This gives a direct connection between the dialer and the telephone line which cannot be interrupted. Line seizure stays in effect until the tape stops.

FCC regulations state that a CC-403 Connecting Cord must be used with the telephone company's jack, USOC-RJ31X, when connecting a telephone dialer into a building's phone system. When line seizure is desired, the CC-403 is connected as shown below.

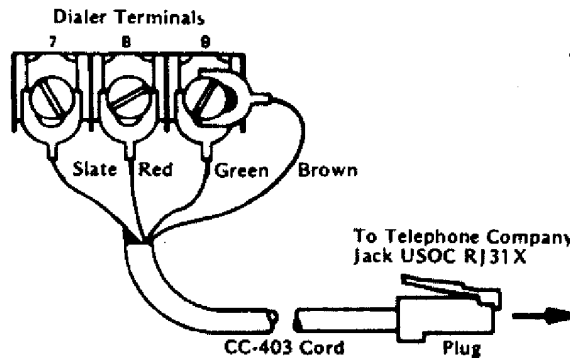

NOTE

- Do not connect dialer to coin or party lines.
- Disconnect dialer if trouble occurs on telephone line.

According to recent FCC rules, telephone couplers are no longer required when using NAPCO dialing equipment. Models MK-5000 & MK-5000R are registered under FCC Number AD898H-62853-AL-R and have been assigned a ringer equivalence of 0.0B.

Where FCC regulations do not apply (as with private phone networks, or in foreign countries), the building's internal and incoming telephone lines can be wired directly to the dialer.

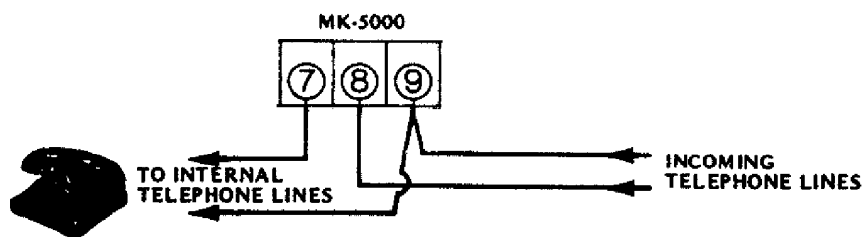

TERMINALS 8 & 9: INCOMING TELEPHONE LINES (Without Line Seizure)

When line seizure is not desired, both the internal and incoming telephone lines are connected to these terminals.

FCC regulations state that a CC-403 Connecting Cord must be used with the telephone company's jack, USOC-RJ31X, when connecting a telephone dialer into a building's phone system. This is done as shown below:

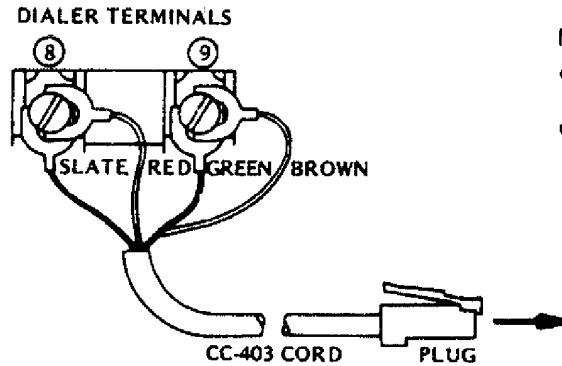

NOTE

- Do not connect dialer to coin or party lines.
- Disconnect dialer if trouble occurs on telephone line.

Registered under FCC #AD898H-62853-AL-R Ringer Equivalence of 0.0B. For connecting without telephone coupler, when using CC-403 Connecting Cord.

To Telephone Company Jack USOC RJ31X

Where FCC regulations do not apply (as with private phone networks, or in foreign countries), the building's internal and incoming telephone lines can be wired directly to the dialer.

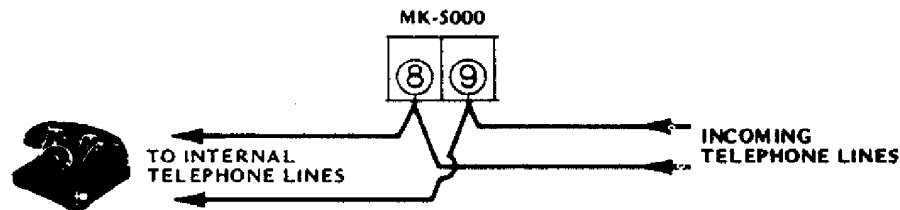

TERMINALS 9 & 10: Voice Check

A Napco HS-1 Telephone Handset can be connected to these terminals to monitor the outgoing message.

TERMINALS 11 (+) & 12 (-): STANDBY DC POWER

MK-5000 can use either a 12 VDC dry cell battery (which should be replaced annually) as stand-by, or a gel type rechargeable battery, such as a Napco RBAT-1, in conjunction with an RM-712 Recharger Module.

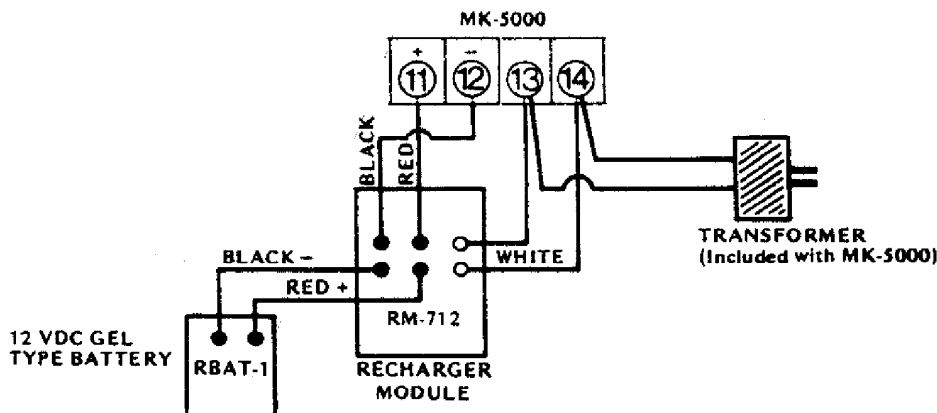

MK-5000R has its own built-in recharging circuitry. A 12 VDC gel type battery, such as the Napco RBAT-1, will be continuously charged when connected to terminals 11 & 12. Do not use dry cell batteries

TERMINALS 13 & 14: 12-VAC INPUT

The included Napco TRF-1 low voltage transformer is wired to these terminals. Care should be taken not to plug the transformer into a socket that might be accidentally shut off.

GROUND THE DIALER

Secure an insulated 16 gauge (minimum) wire to the lower mounting screw, making sure good contact is being made with the cabinet. It is best to chip away some paint and to use a washer of adequate size. Run the wire directly as possible to a 3/4" O.D., or larger, cold water pipe. Do not use a gas pipe or the building's AC ground. The stripped end of the wire must then be soldered or clamped to a clean section of pipe

OPERATING INSTRUCTIONS

TAPE CARTRIDGE

The Mark-5000 can be ordered with a 5 minute (4 messages per channel) tape cartridge. Others are also available for 40 seconds, 3, 8, and 15 minute tape lengths. Tape length is determined by the number and length of the messages that are programmed.

Messages can be programmed onto the tape by most Napco dealers and distributors, or at our factory. For convenience, we suggest the use of a PG-1 Program Generator. This will allow you to program tapes in the field, or to reprogram existing messages.

Tape Information:

Priority Channel — Channel A is usually programmed for burglary messages and Channel B for fire. Should both emergencies occur simultaneously, Channel B will assume priority and place its calls.

Line Release — This prevents an incoming telephone call from tying up the telephone lines during an emergency. It is accomplished by programming a 40 second "hang-up" tone at the beginning of the taped message. With this, the dialer simulates the hanging up of an existing call for 40 seconds, which disconnects the call, and frees the phone lines. Because of the 40 second delay, line release should only be used for burglary emergencies — not fire.

SOLENOID TAPE TRANSPORT

The programmed tape cartridge is lowered into the top of the dialer with the pressure roller passing through the hole in the bottom of the cartridge. There is no threading or looping of the tape. At this point, the cartridge has a loose fit with the roller. Upon alarm (or test), a solenoid slides the tape and roller into contact with the capstan and head. This system insures better message quality and longer tape life.

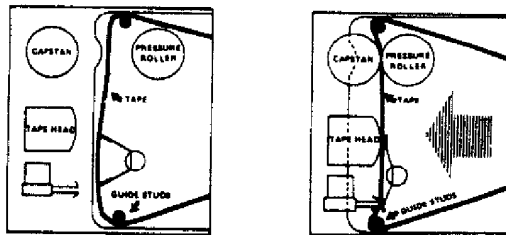

ON/OFF SWITCH

This is a two position rocker switch with an LED, AC power indicator below it. If the "Off" switch is pressed while a message is in progress (this is *not recommended* procedure), the tape will stop completely. The tape will not reset until the switch is placed in the "On" position and either channel is tripped.

NOTE: Turning off the switch of the Mark-5000R will not stop the charging current to the gel type battery.

ABORT/TEST FEATURE

Testing and manual aborting of both channels is accomplished by the use of the two-position momentary rocker switch on top of the unit. After the switch has been depressed in either position, the dialer will automatically run full cycle and reset itself.

TEST: Since Channel B is a priority channel, one should first check Channel A and then, while in the middle of its message, Test B should be activated. This will cause the 'B' message to override the 'A' message and Channel B will be heard over the speaker, but will not be transmitted.

MANUAL ABORT: By pressing either Test A or Test B, a manual abort will be effected. This will remove the message from the phone line; make it audible over the speaker, and automatically reset the dialer.

NOTE: Whenever the Test B switch is used to abort a dial-out on either channel, only the B message will be heard. This is because of the switch's dual function (Test/Abort), and that B is a priority channel.

SPECIFICATIONS

Supply Voltage:	12 VAC, 12 VDC Stand-by
Activation Voltage:	5-18 VDC
Dialing Pulse Rate:	10/second, nominal
Input Impedence:	2000 Ohms on all inputs
Dimensions:	9" H. x 9¾" W. x 6½" D.
Weight:	14 pounds

ORDERING INFORMATION

MK-5	Mark-5000 complete with transformer and tape
MK-5R	Mark-5000 rechargeable with transformer and tape
CC-403	Telephone Connecting Cord — used with RJ31X jack
HS-1	Telephone handset
KEY-1	Set of keys for dialer
LA-1	Lightning Arrester
LED-1	Light emitting diode, in plastic mounting case
MD-402	Master Disconnect Switch — California requirement
MIC-1	Extra microphone
PG-1	Program Generator
PRO-1	Programming
RBAT-1	Rechargeable gel type battery for MK-5R, 12 volt, 4 A.H.
RM-712	Recharger Module - 12 volt (Do not use with MK-5R)
TC-1	Extra Tape Cartridge (specify 40 seconds, 3, 5, or 8 minutes)
TC-2C	Extra Tape Cartridge — Custom
TC-2-15	Extra Tape Cartridge — 15 minutes
TC-3	Demonstration Tape for burglary and fire
TC-4	Demonstration Tape for medical emergency alarm
TRF-1	Extra Transformer
DD-458	Delay Module — delays dialer for 20 seconds before dialing
GSM-400	Ground-Start Module

TROUBLESHOOTING PROCEDURE

If dialer does not function properly after installation, proceed as follows:

1. Disconnect all inputs. Place abort switch in OFF (up) position.
2. Connect a jumper between terminals 4 and 5 and apply power to transformer from terminals 13 and 14. Insert test tape (40-second tape with dial and audio information programmed). Push on/off rocker switch to ON position. Push A/B test-abort rocker switch to test "A" position. Listen to dial data and audio. Repeat for Channel B by pushing rocker to test "B" position and allow tape to continue until it stops.
3. Push on/off rocker switch to ON position with handset connected to terminals 8 and 9. Connect jumper momentarily between terminals 2 and 3. Dialer should engage Channel A. Listen for dial relay energizing and de-energizing with dial information on tape. Repeat for Channel B by connecting a jumper between terminals 3 and 6 momentarily.
4. Audio information should be heard in handset (handset simulates phone line). Place abort switch in ABORT (lower) position. Channel A audio should be muted. Return abort switch to upper position and allow tape to complete its cycle. Remove jumper from terminals 4 and 5. Channel A should engage.

If dialer operates as above, connect external inputs one at a time and look for any abnormal operation. This would indicate a defect in external equipment or in loop. If dialer does not operate as above, return to factory for service.